

Nova Light Dual Flush Cover Plate - 38809



Can be horizontally or vertically mounted



Can set light to yellow, blue, green or red or any tones in-between. Can also set to have a constantly changing spectrum of colours. Can be switched on or /off at any time.

TECHNICAL SPECIFICATIONS

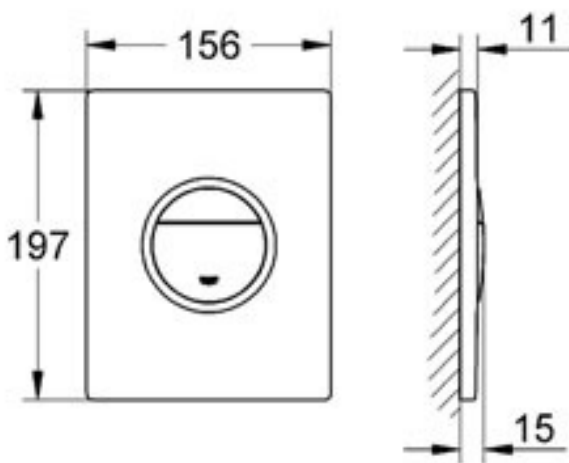

- Supplied with Mains-Powered Multi LED lights
- Includes Transformer for external installation
- Operating voltage 230 V AC 50/60 Hz, 2.0 VA
- Maximum allowable distance from AC adaptor to flush plate is 10 meters

PRODUCT NO: **38809**, Nova Light Dual Flush Cover Plate
supplied with 3meter extension cable from transformer (maximum capacity 10meter)